

Cash Valve Cryogenic Products



Cash Valve Portfolio of Products
Provides solutions for cryogenic tanks and systems.



Liquid-Gas Distribution System Schematic Diagram

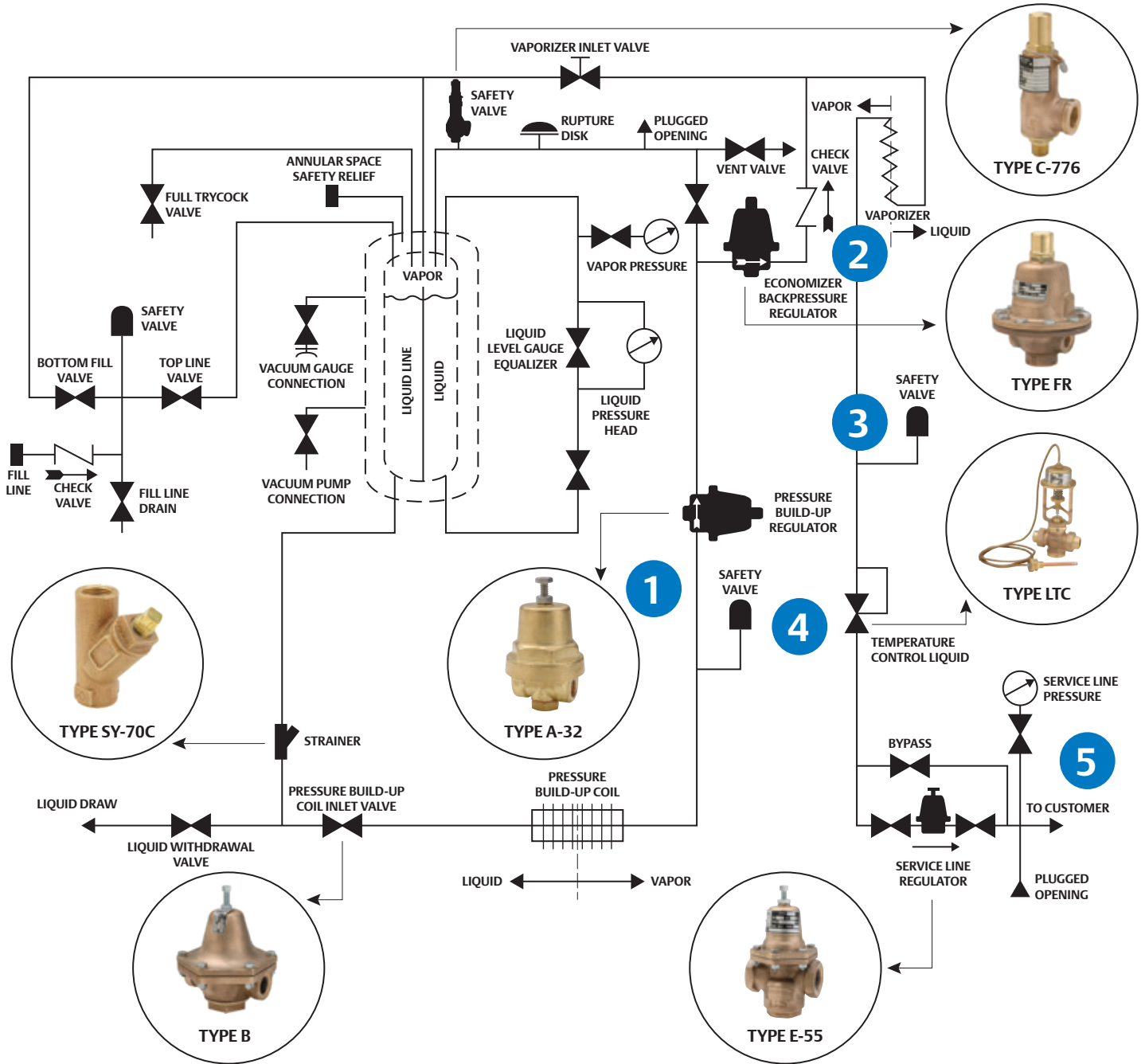

1. Pressure Build Circuit

- Head pressure not sufficient to supply final line so pressure maintained about 25 psi above the service line
- When pressure reaches setpoint, the regulator shuts off, stopping vaporization and pressure build-up. Regulator reopens when demand initiated at the final line
- Takes liquid from base of Dewar, passes through valve and heat exchanger and is vaporized after being warmed by ambient air
- Typically between 125 and 175 psig
- Regulator may be located before or after heat exchanger but makes big difference in valve size

2. Economizer Circuit

- Usually set 10 to 25 psig above the set pressure of build-up regulator
- When no gas being used, heat leakage into the tank causes gas pressure to rise
- Excess pressure bypassed into final vaporizer circuit to prevent losing gas to atmosphere through safety valve

3. Combination Valves

- Combines pressure building and economizer functions
- Economizer function can start just before or when the pressure building pressure is reached

4. Low Pressure Cut-Off Circuit

- Temperature control valve designed to trip when gas temperature reaches a predetermined level (usually -20°F)
- Most common cause is rapid gas draw
- Temperature control valve trips to prevent excessively cold gas from being delivered to service end of system when setpoint reached
- Valve automatically opens when gas temperature rises above setpoint

5. Final Line (House Line)



- Demand causes flow from system first
- Liquid flow passes through heat exchanger and is warmed by ambient air or steam
- Phase change occurs in the vaporizer to convert back to gas
- Pressure controlled using regulator
- Standard elastomers can be used for service line regulator since gas at or near ambient temperature

Cryogenic

Relief Valves

Maximum Inlet Pressure	Outlet Pressure Range	Size	Maximum Capacity		Type Number
600 psig / 41.4 bar	15 to 600 psig / 1 to 41.4 bar	1/2 to 3/4 in.	4800 to 99,060 SCFH / 128.6 to 2654.8 Nm ³ h		C-776 Bronze
500 psig / 34.5 bar	15 to 500 psig / 1 to 34.5 bar	1 to 2 in.	9660 to 817,920 SCFH / 258.9 to 21,920 Nm ³ h		C-776 Bronze
600 psig / 41.4 bar	15 to 600 psig / 1 to 41.4 bar	1/4 to 1/2 in.	1560 to 32,040 SCFH / 41.8 to 859 Nm ³ h		C600 Brass

Isolation Valves and Strainers





Maximum Inlet Pressure	Outlet Pressure Range	Size	Maximum Capacity		Type Number
700 psig / 48.3 bar	----	1/4 to 1/2 in.	----		2300 Brass
400 psig / 27.6 bar	----	1/2 to 2 in.	----		SY-70C Bronze

Pressure Build



Maximum Inlet Pressure	Outlet Pressure Range	Size	Maximum Capacity		Type Number
600 psig / 41.4 bar	2 to 600 psig / 0.1 to 41.4 bar	1/4 to 3/8 in.	2027 SCFH / 54 Nm ³ h		A-32 Bronze
600 psig / 41.4 bar	10 to 400 psig / 0.7 to 27.6 bar	3/8 in.	2027 SCFH / 54 Nm ³ h		A-36 Brass
600 psig / 41.4 bar	20 to 600 psig / 1.4 to 41.4 bar	1/2 in.	----		A-401 Bronze
720 psig / 49.6 bar	5 to 250 psig / 0.3 to 17.2 bar	1/4 to 2 in.	282 to 341,940 SCFH / 8 to 9164 Nm ³ h		B Bronze
720 psig / 49.6 bar	10 to 600 psig / 0.7 to 41.4 bar	1/2 to 1 in.	240 to 57,600 SCFH / 6 to 1544 Nm ³ h		B-95 SST
600 psig / 41.4 bar	5 to 600 psig / 0.3 to 41.4 bar	1/4 to 1 1/2 in.	132 to 7260 SCFH / 4 to 195 Nm ³ h		G-60 Bronze, SST
400 psig / 27.6 bar	25 to 300 psig / 1.7 to 20.7 bar	1/2 to 2 in.	240 to 8400 SCFH / 6 to 225 Nm ³ h		E-55 Bronze
2400 psig / 165.5 bar	1 to 250 psig / 0.1 to 17.2 bar	3/8 to 3/4 in.	7500 to 42,000 SCFH / 201 to 1126 Nm ³ h		LS Bronze

Cryogenic

Backpressure Regulators (Economizers)

Maximum Inlet Pressure	Outlet Pressure Range	Size	Maximum Capacity		Type Number
520 psi / 35.9 bar	0 to 400 psig / 0 to 27.6 bar	1/2 to 2 in.	Gas: 420 to 90,000 SCFH / 11.3 to 2412 Nm ³ h Liquid: 1.5 to 162 gpm		FR Cast Iron, Bronze
780 psi / 53.8 bar	200 to 600 psig / 14 to 41.4 bar	1/2 to 2 in.	Gas: 3600 to 126,000 SCFH / 96.5 to 3376 Nm ³ h Liquid: 10 to 162 gpm		FR-6 Cast Iron, Bronze
325 psi / 22.4 bar	0 to 250 psig / 0 to 17.2 bar	1/2 to 2 in.	Gas: 420 to 45,000 SCFH / 11.3 to 1206 Nm ³ h Liquid: 1.5 to 82 gpm		FR-10 Cast Iron, Bronze
720 psi / 49.6 bar	0 to 250 psig / 0 to 17.2 bar	1/8 to 3/8 in.	Gas: 18 to 2100 SCFH / 0.5 to 56 Nm ³ h Liquid: 0.2 to 1.5 gpm		FRM Brass, SST



Pressure Build Economizers

Maximum Inlet Pressure	Outlet Pressure Range	Size	Maximum Capacity		Type Number
600 psig / 41.4 bar	50 to 300 psig / 3.4 to 24.1 bar	1/4 in.	----		PBE-1A Brass
400 psig / 27.6 bar	10 to 250 psig / 0.7 to 17.2 bar	1/2 in.	----		PBE-2 Bronze
650 psig / 44.8 bar	0 to 650 psig / 0 to 44.8 bar	1/2 in.	----		PBE-5 Brass

Low Temperature Cutoff

Maximum Inlet Pressure	Outlet Pressure Range	Size	Maximum Capacity	Type Number
400 psi / 27.6 bar	----	1/2 to 2 in.	147,268 SCFH / 3947 Nm ³ /h	 LTC Bronze

Final Line

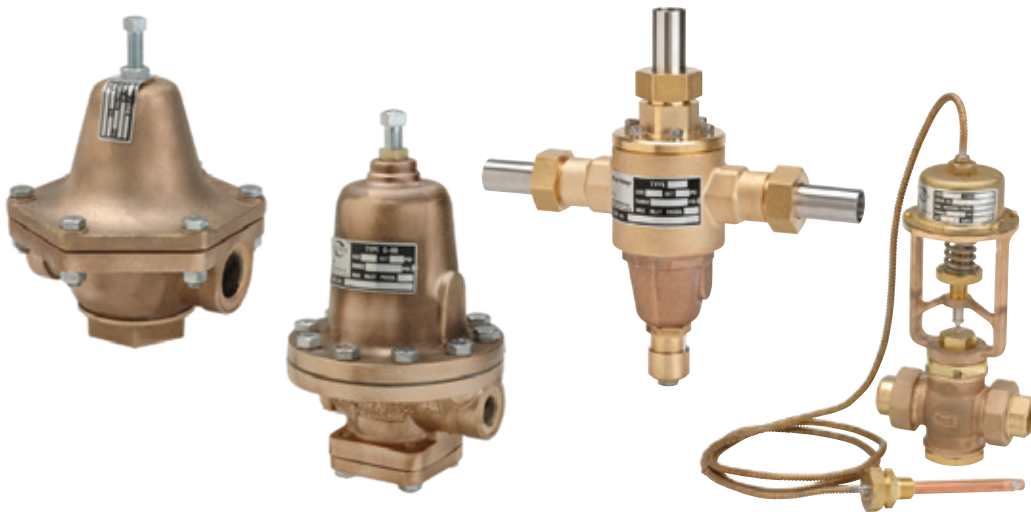

Maximum Inlet Pressure	Outlet Pressure Range	Size	Maximum Capacity	Type Number
400 psig / 27.6 bar	25 to 300 psig / 1.7 to 20.7 bar	1/2 to 2 in.	240 to 8400 SCFH / 6 to 225 Nm ³ /h	 E-55 Bronze
400 psig / 27.6 bar	2 to 175 psig / 0.1 to 12.1 bar	1/4 in.	480 to 3240 SCFH / 13 to 87 Nm ³ /h	 A-31 Brass
600 psig / 41.4 bar	20 to 600 psig / 1.4 to 41.4 bar	1/2 in.	----	 A-401 Bronze

Cash Valve Cryogenic Products



Cash Valve

Americas
T +1 800 558 5853
T +1 972 548 3574

 webadmin.regulators@emerson.com
 CashValve.com

Europe
T +39 051 419 0611

Asia Pacific
T +65 6777 8211

Middle East / Africa
T +971 4811 8100